

Objective

Amazing high resistance die cast aluminium body in a tested IP 66 which means we are speaking about a high bay light, mainly for industrial application with IK 10 or high mounting large space area applicable for indoor and outdoor installer, with all the characteristics to be fixed outside, in the canopy for instance. IP 66 means the item is highly resistant to hard meteorological conditions and highly humid weather. Very simple design, top resistance.

Obiettivo

Incredibile corpo in alluminio pressofuso ad alta resistenza in un IP 66 collaudato, il che significa che stiamo puntando su un'alta luce della baia, principalmente per applicazioni industriali con IK 10 o area di montaggio elevata con ampio spazio applicabile per installatori interni ed esterni, con tutte le caratteristiche da fissare fuori, nel baldacchino per esempio. IP 66 significa che l'articolo è altamente resistente alle difficili condizioni meteorologiche e al clima molto umido. Design molto semplice, massima resistenza.

Description

Housing - Made of die cast aluminum powder coating.

Diffuser - Polycarbonate optical lens.

LED - reducing energy consumption with L80/B10/F10 70,000 hrs lifetime.

Standards - manufactured in accordance with EN 60598-1 and 60598-2-1

Mounting Option - Ceiling Hanging, Wall Mounting with bracket.

Microwave Motion Sensor - 100W ~ 240W Available only

CODE	WATTAGE	LUMEN	SIZE mm
17003100	100W	19000lm	Ø360 X 186H
17003120	120W	22800lm	Ø360 X 186H
17003150	150W	28500lm	Ø360 X 186H
17003200	200W	38000lm	Ø360 X 186H
17003240	240W	45600lm	Ø360 X 186H
17003300	300W	57000lm	Ø360 X 190H





65°C Applications Available
Vertical installed driver & special heatsink design allows its enduring lifetime in some high temperature applications.



Emergency Backup Solution
Square and horizontal installed driver can compatible with 8W back up battery that supports 3hours lighting, which works fine

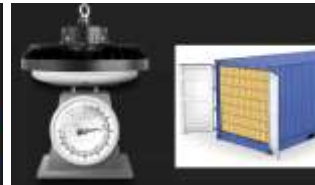

Light in Weight. 300W only 4.3kg.
Lighter weight for easier installation and transportaion to lower maintenance and shipping cost.



Better Heat Dissipation
One size heat sink for power ranges from 100W 120W 150W 200W 240W 300W.

MICROWAVE MOTION SENSOR	10 YEARS WARRANTY
LED ENERGY SAVING	ECO
PHASE DIMMING	DALI 1-10 DIMMING
55°C -25°C	Glowing Wire Test - 850°
IP 66	IK 10
UGR <22	SDCM 2.0/3.0
CIDET	EAC
COMPLIANCE LM-78 TM-21 LM-80	
PASEL ACCREDITATION	SMD
CRI >90	
SELV	series wiring
ROHS	
CE	COMPLIANCE
A++	85-265V 50/60Hz



PC Lens



Safety

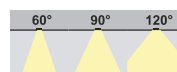
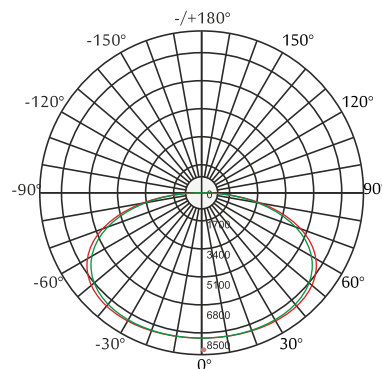
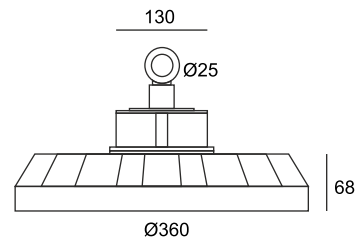

- 2700K
- 3000K
- 4000K
- 5000K
- 6000K
- 6500K



LED Drivers - PHILIPS **GTI** **MEAN WELL**

LED Chips - PHILIPS

In a continuing effort to offer the best product possible, we reserve the right to change, without notice, specifications or materials that in our opinion will not alter the function of the product. Specification sheets found at www.romaluce.it are the most recent versions and supercede all other printed or electronic versions.